



Exergoecological Evaluation of Power Generation in Steam Cycles Fed by Biomass

Jesús D. Rhenals-Julio*, María K. Galván Castilla, Stiven Peralta Jorge, Jorge M. Mendoza

Department of Mechanical Engineering, University of Córdoba, Cra 6 No. 77- 305 Montería, Colombia.

*Email: jesusrhenalsj@correo.unicordoba.edu.co

Received: 29 December 2022

Accepted: 10 March 2023

DOI: <https://doi.org/10.32479/ijeep.14104>

ABSTRACT

One of the methods to reduce environmental impacts is to use renewable resources such as biomass or even waste. In this work, a novel power generation system in biomass-powered steam cycles was proposed, comprising biomass gasification, a steam turbine, a pump and a condenser. A biomass feedstock (rice husk) was used in the gasifier as input fuel. The devised system was analyzed taking into account the sustainability evaluation that includes thermodynamic and environmental parameters. An energetic, exergetic and exergoecological analysis was carried out. In addition, a detailed sensitivity analysis was performed to assess the effects of varying operating parameters on system efficiency. According to the results, the energy and exergetic efficiencies of the system had a value of 23,680% and 12,830%, respectively, where the boiler and the turbine presented the highest average environmental impact per input and output exergy. The components with the highest environmental impact index associated with exergy destruction were the condenser and the boiler, representing 99,82%, demonstrating profit margins in the formation of pollutants and exergy destruction. The entire system had a total ecological impact of 2.614 mPt/s and can be reduced mainly by improving its exergetic efficiency. Exergoecological assessments can be used to support power generation in complex cycles, especially to reduce the generation of environmental pollution.

Keywords: Exergoecology, Exergy, Rankine Cycle, Biomass, Rice Husk

JEL Classifications: C6, Q2, Q4, Q5

1. INTRODUCTION

The increase in population and the increase in living standards have led to great concern worldwide about the effect of energy demand on industrial processes (Rostami et al., 2022) together with the need to find tools that can help in the global sustainable development and optimal use of natural resources, a fact that promotes the integration of multiple generation systems to renewable energy resources to help overcome environmental problems related to the use of traditional fuels (Dincer and Zamfirescu, 2012). Problems such as the depletion of fossil fuels, security of supplies and environmental sustainability lead to the search for using other types of fuels and renewable energy sources that represent a gain from the financial and environmental point of view, providing good energy efficiency. The Colombian energy matrix is made up mainly of non-renewable energy sources

(62%), with oil, diesel and petroleum derivatives being 46% and natural gas 16%. In this matrix for the supply of renewable energies we find 17% in electrical energy, 7% for other alternatives and biomass participates in 14%, being the most representative for generating sustainable energy (Buitrago, 2022). Biomass is a biological material obtained from living organisms that, after gasification processes, produces gases that can be used as fuels (Méndez, 2010). These can be found with different contents in most regions of the earth. Biomass sources can include municipal, agricultural, paper or forest residues. Sustainability and lower pollutant emissions are the most significant advantages of commonly used biomass fuels, such as paper, wood, straw waste, sawdust and rice husks (Cao, 2022).

When studying the world production of rice, according to the FAO, for 2017 it was close to 759,600,000 tons, while in Colombia

2,700,000 tons were produced (FAO, 2018). Of the total rice production in Colombia, 18% of the total weight represents husk, which leaves as production of this biomass: 450,000 tons/year (Méndez, 2010). Currently in Colombia the use of residual biomass from rice production is not adequately used. One of the ways to eliminate this residue is to burn it, causing the production of unburned substances such as CO, C and H₂. Which are the most common pollutants that escape into the atmosphere in combustion gases (BOTTA, 2012).

The energy potential for the generation of clean energy from rice husks was confirmed by Valverde et al. (2007), who presented a physicochemical analysis of rice husk samples taking different parts of the world as matrices, conclude that regardless of the place of origin of the rice husk, the results of the energy potential are similar to produce electrical energy and that said data show 67% of calorific value in relation to combustion. The generation of energy from rice husks resulted in considerable advantages in terms of energy viability because this type of waste is capable of providing enough energy for any process with minimal environmental impact (Quintero, 2017). Power generation from rice husks can be very important in Colombia, since rice can be harvested at any time of the year, the period can coincide with periods of high or low rainfall (reservoir levels hydroelectric). The use of rice husk for energy purposes can guarantee the energy self-sufficiency of an industry, with the possibility of selling energy and obtaining economic benefits.

Rice husk-based power generation has been the focus of many energetic, economic, and exergetic analyses. Quispe et al. (2019) analyzed the current scenario of energy resources in Peru and verified the potential of rice husk. Life cycle assessments were developed to obtain energy production from this biomass, and the research confirmed rice hulls as a suitable alternative for energy generation with economic, environmental, and social advantages.

However, modern systems for power generation need to go one step beyond thermodynamic performance analysis alone and include environmental assessments due to the rise of widespread environmental awareness around the world (Cavalcanti et al., 2020). Exergy provides information on the quality of energy and is very appropriate to assess the thermodynamic efficiency of energy conversion processes, playing an important role in increasing the use of green energy and technologies (Bilgen and Sarikaya, 2015). As discussed by Kamari et al. (2022). Those who carried out an energy, exergetic and environmental study of an integral plant assisted by biomass for polygeneration fed by various sources of biomass, where they obtained the energy efficiencies of the system and the environmental impacts according to each biomass, concluded that the rice husk had the lowest energy efficiency compared to the other biomasses, with 71,2%, but obtained the highest exergetic efficiency with 31,61%, they also concluded that the highest values of carbon dioxide emissions were achieved with rice husks. CO₂ compared to the other biomasses.

On the other hand, focusing on exergoecological assessment, exergetic analysis is complemented by environmental information provided by life cycle assessments, which quantify the

environmental impacts of a product during its life. Cavalcanti et al. (2019) developed exergoeconomic and exergoecological comparisons for a diesel engine generator powered with different blends of diesel and biodiesel and found that the addition of biodiesel reduced the specific environmental impact of electricity. Similarly observed, Shafie et al. (2011). Based on the life cycle assessment of electricity generation from rice husk in Malaysia, they reported on the characterization of electricity derived from rice husk compared to electricity derived from coal and natural gas and concluded that the performance of electricity derived from rice husk is better in the aspect of environmental impact parameters.

However, despite the fact that there is currently great concern about the environmental impact caused by power generation cycles, the literature on these topics is very short in terms of exergetic and exergoecological evaluations of steam cycles fed by biomass. Therefore, in this work we start from an ideal cycle (Rankine cycle) for steam power plants, whose fuel is rice husks. With this, the technical and environmental feasibility of this simple cycle was evaluated, so that future research on the environmental impact of steam cycles starts from this study.

Finally, the novelties of this research are listed, intended to further expand the existing knowledge base: (i) application of the exergoecological analysis approach, based on the Eco-indicator 99 method, to a power generation cycle fed with husk of rice; (ii) evaluation of the environmental impact rate per power exergy and comparison with other conventional and renewable sources of power generation, and (iii) performance of sensitivity analysis to investigate the impacts of effective decision variables on results and efficiencies.

Exergoecological balances are developed to quantify the environmental impact of each component of the system, obtaining the environmental impact rate per exergy unit of power. The exergoecological factors of all the components of the system are evaluated to determine the components with the lowest environmental performance and provide information on trends and possibilities for improvement in the project. The results provide theoretical information on a steam cycle burning rice hulls and allow a detailed comparison with data from the literature. These evaluations help in the decision-making process, directing investments towards environmentally friendly power production.

2. MATERIALS AND METHODS

In this section the biomass powered power generation system is presented and details about the energy, exergy and exergoecology evaluations are provided.

2.1. System Description

The schematic configuration of the power generation system in the steam cycle is represented in Figure 1. The combustion gas production process is obtained through a mixture and burning of rice husks (a) with air (b) in a boiler. The heat originated by these gases is transferred to the water at constant pressure and converts it into superheated steam, after making the heat transfer, the exhaust gases (c) leave the boiler to the environment. The

superheated steam (#1) leaving the boiler at 900°C and 12,50 MPa drives the steam turbine (TURB) with an outlet pressure of 0,10 MPa. This turbine generates 26,97 MW of energy, and the output steam (#2) from the TURB changes phase in the condenser (COND), becoming a saturated liquid (#3) that is compressed in a pump (BOMB) before entering the boiler (#4) and returning to the power generation cycle.

System operation data was compiled from a power generation analysis of a thermoelectric plant by Marrugo et al. (2014). And steady state conditions are considered for the system:

- The isentropic efficiency of the boiler feed pump is 75% and it has an outlet pressure of 12,50 MPa
- The mass flow of the water vapor that circulates through the cycle is 1 kmol/s
- Atmospheric air is at 25°C and 101,15 kPa. The gases exchange heat in the exchanger and leave at 560°C, with constant pressure
- The temperature and pressure of the water vapor at the exit of the exchanger are 900°C and 12,50 MPa, respectively
- The isentropic efficiency of the turbine is 93% and it has an outlet pressure of 103 KPa equal to that of the condenser.

2.2. Energy Analysis

Combustion is a chemical process in which a fuel is oxidized through a chemical reaction, resulting in energy and combustion products. All combustion requires an oxidizing agent and a fuel, the most frequently used oxidant is air, because it is very affordable. Air consists of a mixture of 21% oxygen, 78% nitrogen, and 1% other gases such as argon, helium, neon, etc. They are found in small amounts and are considered as nitrogen. Consequently, for 1kmol of O₂ entering a combustion chamber, there will be 3.76 kmol of N₂, which add up to 4.76 kmol of air. On the other hand, the fuels that are mainly used are based on hydrocarbons that are mainly composed of hydrogen and carbon, denoted by the general formula C_nH_m (Cengel and Boles, 2009). However, the fuels that come from biomass are denoted by the general formula CH_nO_sN_n (Méndez, 2010). Rice husk is a biomass that presents interesting chemical properties such as low phosphorus content and high cellulose content that makes it suitable as biomass in combustion

processes (Méndez, 2010). Table 1 shows the elemental analysis made by (Méndez, 2010).

According to (Méndez, 2010), the composition of the wet rice husk (mass basis) it is 37.64% C, 4.66% H, 0.87% N, 28.69% O, 22.48% water (H₂O) and 5.66% ash. The mole fractions of the main components of the rice husk (carbon, hydrogen, oxygen, nitrogen) should be calculated.

The combustion reaction can be written per kmol of rice husk, as equation (1):

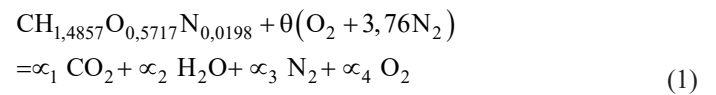

θ is the theoretical amount of air. α represents the stoichiometric coefficients of the gaseous combustion products evaluated by the balance of chemical species. θ is considered as 0.2.

Considering an adiabatic combustion process, according to He et al. (2022) the energy conservation equation for the considered combustion process can be presented as follows:

$$\sum_k X_k (\bar{h}_{f_k}^0 + \Delta\bar{h})_{Gas} + \sum_k X_k (\bar{h}_{f_k}^0 + \Delta\bar{h})_{Air} = \sum_k X_k (\bar{h}_{f_k}^0 + \Delta\bar{h})_{products} \tag{2}$$

X is the number of moles of reactants and products in the combustion reaction, hf 0 is the enthalpy of formation of each substance, and Δh is the change in enthalpy of formation in relation to the dead state.

The calorific value (LHV) was studied by Méndez (2010), and has a value of 12903 kJ/kmol.

On the other hand, the mass and energy balances considering the steady state are applied to the energy system to find the mass flow rates, the thermodynamic properties of each flow, the power of the system and the thermal energy of the process Cavalcanti et al. (2020). The effects of potential and kinetic energy are not considered.

2.3. Exergetic Analysis

The exergy of a system is the maximum useful work that can be obtained from the system in a specific state (Cengel and Boles,

Figure 1: Schematic diagram of the power generation system

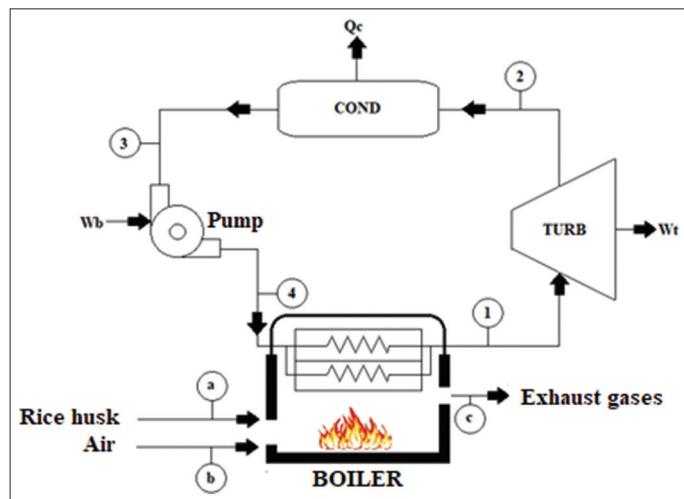

Table 1: Elemental analysis of rice husk (Méndez, 2010)

Rice husk composition	Mass percentage
Residual moisture	5.66
volatile matter	65.41
Ash	22.48
fixed carbon	6.45
Carbon	37.64
Hydrogen	4.66
Nitrogen	0.87
Oxygen	28.69

2009). Ambient conditions (dead state) are 25°C and 101 kPa. Exergy is made up of four subcomponents which are physical exergy, chemical exergy, kinetic exergy, and potential exergy. Sometimes, the kinetic and potential exergies are neglected because they have low values (He et al., 2022). Then, the specific exergy for the system is given by equation (3).

$$b = b^{ph} + b^{ch} \quad (3)$$

Where, b^{ph} denotes the physical exergy and can be calculated with equation (4) (Rhenals and Torres, 2016).

$$b^{ph} = h_i - h_o - T_o (s_i - s_o) \quad (4)$$

The chemical exergy of the rice husk is estimated using the method used by Rhenals and Torres (2016). In which the chemical exergy for the solid biomass fuel is described by the following equations (5) and (6).

$$b_{biomass}^{ch} = \beta \cdot LHV_{biomass} \quad (5)$$

$LHV_{biomass}$ is the lower calorific value of the biomass, in this case of the rice husk, and β is the ratio between the chemical exergy and the lower calorific value of the biomass. β It can be calculated as follows (Rhenals and Torres, 2016):

$$\beta = \frac{1,0414 + 0,0177 \left(\frac{H}{C} \right) - 0,3328 \left(\frac{O}{C} \right) \left[1 + 0,0537 \left(\frac{H}{C} \right) \right]}{1 - 0,04321 \left(\frac{O}{C} \right)} \quad (6)$$

Where C, H and O represent the percentage of carbon, hydrogen and oxygen, respectively, in the biomass. On the other hand, the chemical exergy for ideal gas mixtures is presented by equation (7) (Rhenals and Torres, 2016):

$$b_{gas}^{ch} = \sum_i X_i b_{i0}^{ch} + \bar{R}T_o \sum_i X_i \ln(X_i) \quad (7)$$

Where X_i represents the mole fraction of each component and b_{i0}^{ch} is the standard chemical exergy (Rhenals and Torres, 2016). The standard molar chemical exergy values for CO_2 , H_2O , N_2 and O_2 are: 19870, 9500, 720, and 3970, respectively. These values were obtained from Morris (1988).

On the other hand, the exergy balances for each of the control volumes of the system can be represented as in equation (8) (Cengel and Boles, 2009).

$$\sum \dot{B}_{i,k} = \sum \dot{B}_{o,k} + \phi \quad (8)$$

Where \dot{B}_i is the exergy into and \dot{B}_o denotes the fraction out of the control volume. Also, ϕ it indicates the portion of exergy destroyed.

The exergetic efficiency (ϵ_k) of the kth component is defined as the ratio between the output exergies and the input exergies (Bejan et al., 1995) and is shown in Equation (9):

$$\epsilon_k = \frac{\dot{B}_{o,k}}{\dot{B}_{i,k}} \quad (9)$$

Table 2 shows the mass, energy and exergy balances for each component of the system.

2.4. Exergoecological Analysis

The exergoecological evaluation is in charge of quantifying the environmental performance of an energy system (Cavalcanti et al., 2020). EI99 was used to express the environmental impacts obtained via LCA and indicates the environmental impact in terms of a single index measured in points (Pts) or millipoints (mPts). One point represents one thousandth of the annual environmental load of an average European inhabitant (Goedkoop, 2000).

On the other hand, the ecological impact per unit of exergy j_k is defined by $\dot{J}_k = \dot{E}_k j_k$ where the environmental impact rate \dot{J}_k is expressed in eco-indicator points per unit of time, for example, eco-indicator 99pts/s. The exergy-based specific environmental impact $J_{D,k}$ (also called specific environmental cost) is the average environmental impact rate per unit of exergy (Pt/exergy or mPt/exergy) (Meyer, 2009).

The balances of ecological impact of the kth component are expressed through equations (10) and (11).

$$\dot{J}_{i,k} = \dot{J}_{o,k} + \dot{Y}_k \quad (10)$$

$$\dot{J}_{o,k} \cdot \dot{E}_{o,k} = j_{i,k} \cdot \dot{E}_{i,k} + \dot{Y}_k \quad (11)$$

$\dot{J}_{i,k}$ and $\dot{J}_{o,k}$ represent the ecological impact rates at the input and output of each component [mPt/s], respectively, $j_{i,k}$ and $j_{o,k}$ are the corresponding average ecological impacts per unit exergy [mPt/kJ] for the input and output of the component, respectively, and Y_k is the ecological impact rate of the component [mPt/s] (Cavalcanti et al., 2020).

The ecological impact of exergy destruction $\dot{J}_{D,k}$ identifies the ecological impact due to exergy destruction within the kth component (Cavalcanti et al., 2020):

$$\dot{J}_{D,k} = \dot{J}_{o,k} \cdot \phi_k \quad (12)$$

Table 2: Mass, energy and exergy balance equations for the components of the system

Component	Mass balance	Energy balance	Exergy destruction rate
Boiler	$\dot{N}_4 = \dot{N}_1$	$Q_{in,cal} = \dot{N}_{vapor} (h_1 - h_4)$	$\phi_{Cald} = \dot{B}_{Biomasa} + \dot{B}_4 - \dot{B}_1 - \dot{B}_C$
Turbine	$\dot{N}_1 = \dot{N}_2$	$W_t = \dot{N}_{vapor} (h_1 - h_2)$	$\phi_T = \dot{B}_1 - \dot{B}_2 - \dot{B}_{W_t}$
Condenser	$\dot{N}_2 = \dot{N}_3$	$Q_c = \dot{N}_{vapor} (h_2 - h_3)$	$\phi_C = \dot{B}_2 - \dot{B}_3 - \dot{B}_{Q_c}$
Bomb	$\dot{N}_3 = \dot{N}_4$	$W_b = \dot{N}_{vapor} (h_3 - h_4)$	$\phi_B = \dot{B}_3 - \dot{B}_4 - \dot{B}_{W_b}$

The total ecological impact associated with the nth component is provided by and identifies the ecological relevance of the component in the system being studied, as expressed by equation (13), (Cavalcanti et al., 2020):

$$\dot{J}_{TOT,i} = \dot{J}_{D,k} + \dot{Y}_k \tag{13}$$

The relative difference of the ecological impact ($r_{j,k}$) and the exergoecological factor ($f_{j,k}$) are used to evaluate the exergoecological performance of each component within the system. ($r_{j,k}$) is the relationship between the increase in the average ecological impact and the average ecological impact of the input and is given by equation (14):

$$r_{j,k} = \frac{\dot{J}_{o,k} - \dot{J}_{i,k}}{\dot{J}_{i,k}} \tag{14}$$

$r_{j,k}$ indicates the potential to reduce the ecological impact of a component (Cavalcanti et al., 2020). A relatively high value of ($r_{j,k}$) indicates components whose ecological impact of the product can be reduced with less effort, compared to components with a lower value $r_{j,k}$. The exergoecological factor expresses the relative contribution of the ecological impact related to the component Y_k to the sum of the ecological impacts associated with the kth component:

$$f_{j,k} = \frac{\dot{Y}_k}{\dot{J}_{D,k} + \dot{Y}_k} = \frac{\dot{Y}_k}{\dot{J}_{TOT,k}} \tag{15}$$

The ecological impact related to the component Y_k is dominant when the value of $f_{j,k}$ is greater than approximately 0.7; however, when exergy destruction is the dominant source of environmental impacts, the value of $f_{j,k}$ becomes less than about 0.3 (Cavalcanti et al., 2020).

For the components that make up the Rankine cycle under study, the ecological impact rate of the turbine (\dot{Y}_{turb}), the pump (\dot{Y}_{bomb}), the condenser (\dot{Y}_{cond}) and the boiler (\dot{Y}_{cald}) are: 0.006, 4.000×10^{-5} , 0.022 and 0.020, respectively. In addition, the ecological impact rate in the pump ($\dot{J}_{i,bomb}$), for the water ($\dot{J}_{i,Agua}$) and for the Q of the condenser ($\dot{J}_{o,cond}$) They are: 0.004, 6.785×10^{-5} and zero, respectively. These data were taken from Nasruddin et al. (2020).

On the other hand, to amplify the effect of plant size on ecological impact measurements and determine the minimum size to have low emissions, the second derivative criterion must be applied. The second derivative test is a theorem to carry out a proof corresponding

to the relative maxima and minima of a function. To determine the size of the plant and obtain low emissions, it is defined as equation (16) (Gutiérrez et al., 2018). To determine the size of the plant and obtain low emissions, it is defined as equation (16).

$$J_{wt} = \frac{J_{wt, y3} - (2J_{wt, y2}) + J_{wt, y1}}{2(W_{neto, x3} - W_{neto, x1})^2} \tag{16}$$

Where the subscripts y3, y2 and y1 correspond to each of the values of the ecological impact according to the W_{net} that the plant would perform, and x3, x1 are the values of the W_{net} to obtain the $J_{wt, y3}$ and $J_{wt, y1}$ of the plant.

3. RESULTS AND DISCUSSION

From the data of the elemental analysis of the rice husk carried out by (Méndez, 2010). The combustion analysis for the Rankine steam cycle is carried out, taking into account an excess of air of 20%. Solving equation (1) and by means of the combustion energy balance, a flame temperature of 1189°C was obtained. The data were obtained using an EES (Engineering Equation Solver) software code.

After solving the combustion analysis, the data obtained were used as input parameters to carry out the energy, exergetic and exergoecological balances. Table 3 shows the data of the molar flows, as well as the temperature, pressure, exergetic indices and environmental impact indices.

The combustion of rice husk has an air-fuel ratio of 6.18 kmol air per kmol of rice husk and at the exit of the combustion gases N_2 has the highest mass composition with a value of 28.834%, followed by CO_2 with 15.682%.

On the other hand, the power generated by the turbine is 26.969 MW, the power consumed by the pump is 310.8 kW, and the heat output from the condenser is 43.841 MW, thus obtaining a net power of 26.658 MW. Under these operating conditions, the Rankine cycle was able to produce an efficiency of 23.680%, which is below the average thermal efficiency of an ideal Rankine cycle of 30%. This low efficiency of the cycle is due to the fact that the gases leaving the combustion chamber do not exit at such high temperatures, so the heat transfer to the working fluid is not high enough to achieve higher efficiency.

Table 3: Results of the energy, exergetic and exergoecological balances of the Rankine cycle fed with rice husks

Spot	Condition	$\dot{N} \left[\frac{kmol}{s} \right]$	$T \left[^\circ C \right]$	$P [kPa]$	$\dot{B} [kW]$	$j \left[\frac{mpt}{s} \right]$
a	Rice husk	0.379	25	100	207835.450	0
b	Air	2.345	25	100	0	0
c	Hot gases	2.725	1189	100	121213.450	0
C'	Exhaust gases	2.725	500	100	52924.950	0
1	Water steam	1	900	12500	74913	1.843
Two	Water steam	1	189.800	103	47827	0.440
3	Saturated liquid	1	189.800	103	6898	0.470
4	Saturated liquid	1	102.400	12500	7204	1.840

The effect of the relationship of the outlet temperature of the gases T_{ad} in the combustion chamber presenting and not presenting excess air is shown in Figure 2. For the exit of the combustion gases, it is possible to determine that the temperature decreases as the excess air in the combustion chamber increases, and is self-explanatory with the presence of O_2 in hot gases, in addition the excess air is heated at the expense of combustion heat, lowering the temperature of the flame, and as an effect the mass of the combustion gases increases, losing a high fraction of heat in the exhaust gases (Buelvas, 1995). The results of the energy, exergy and exergoecological balance are shown in Table 3.

Figure 2 shows the relationship of exhaust gas outlet temperature with the percentage of excess air.

3.1. Exergetic Value of the System

The exergy balances were made for each component of the system, using the input exergy and the output exergy in each component.

Table 4 Shows the destruction exergy rate (ϕ), the input exergy (B_i) and output exergy values (B_o) of each component, and the exergetic efficiency (ϵ).

The results of the exergy analysis showed that the highest input and output values in the components were located in the boiler and in the turbine, this is due to in the boiler, the combustion chamber converts the chemical exergy of the rice husk into energy in the form of heat and the turbine is the component that generates power from the energy of water vapor. Furthermore, boiler and pump present the highest and lowest value of destruction exergy of the system, respectively.

On the other hand, the turbine and the pump have the highest values of exergetic efficiency, while the condenser has the lowest value

Table 4: Parameters of exergy of the components of the Rankine cycle

Component	B_i [kW]	B_o [kW]	ϕ [kW]	ϵ [%]
Boiler	215039.452	127837.950	87191	59.449
Turbine	74913	74796	117	99.900
Condenser	47827	9693	38135	20.260
Bomb	7208.800	7204	5.222	99.930

Figure 2: Flame temperature with respect to excess air

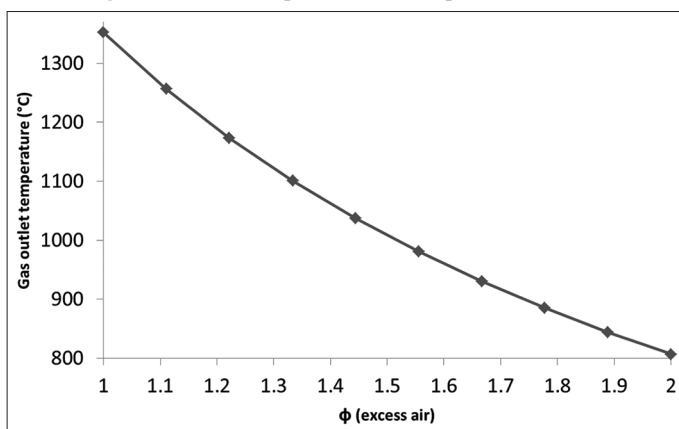

of all the components. The total exergy destroyed by the system is 125448.222 kW, of which the boiler contributes 87.191 kW. The reason for this is due to the chemical exergy destruction of the rice husk.

The total exergetic efficiency of the system is 12.830%, a similar value obtained by Cavalcanti et al. (2020), who used sugarcane bagasse to analyze an energy cogeneration system and obtained an exergetic efficiency of 19.73%, due to the high moisture content, equal to the research carried out by Cavalcanti et al. (2019). That they obtained an exergetic efficiency of 16.89%, because they consumed a lot of heat to evaporate the humidity of the eucalyptus that they used as biomass. These low efficiency values are indicators to improve the performance of these cycles, such as the use of exhaust gases to reduce humidity.

Figure 3 Shows the part of total exergy destroyed by component. The CC is responsible for most of the destruction rate with a value of 69.046%. Other studies that have used biomasses as fuel present similar results, such as Singh, (2020) with 68.22% and Cavalcanti et al. (2019) with 83.28%.

3.2. Exergoecological Analysis of the Rankine Cycle

Table 5 Presents the evaluation of the exergoecological impact by input and output exergy in each component, the environmental impact related to the components, the rate of ecological impact by exergy of destruction, the sum of the ecological impact of the components and the exergoecological factor of the system.

The turbine has the highest ecological impact at the input because it generates the power of the system followed by the boiler that generates the hot gases that generate heat for the cycle, to this is added that the turbine uses the steam that comes out of the product of the heating generated by the boiler. On the other hand, this higher value that enters the turbine is due to the high rate of destruction of chemical exergy that exists within this process (combustion).

Likewise, the condenser next to the boiler presents the highest environmental impact index associated with exergy destruction. Both components represent 99.82% of the total ecological impact associated with the exergy destruction of the system. Also, the

Figure 3: Percentage exergy of destruction of each component

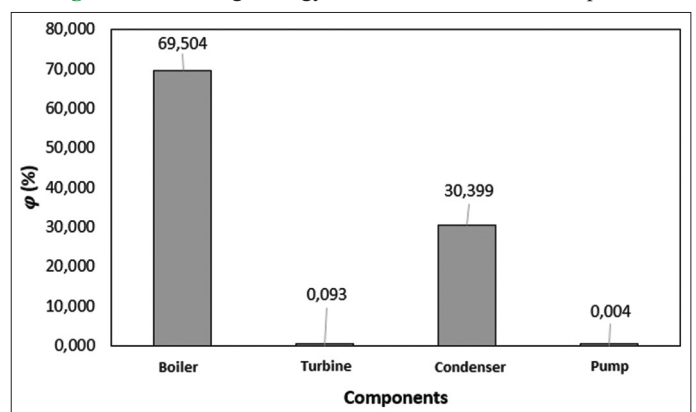
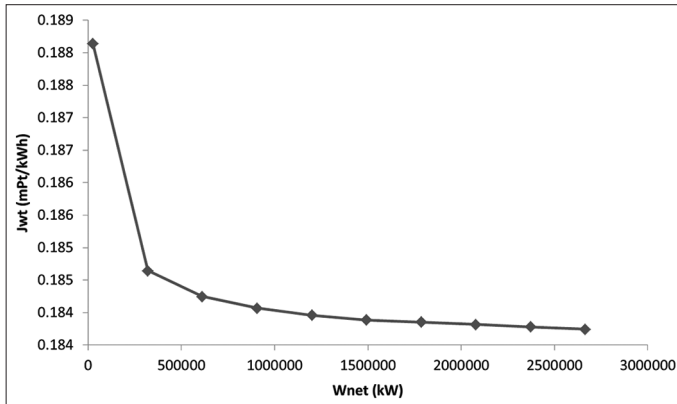

Table 5: Parameters of the evaluation of the exergoecological impact of the components of the Rankine cycle

Components	$j_i \left(\frac{mPt}{MJ} \right)$	$j_o \left(\frac{mPt}{MJ} \right)$	$\dot{Y} \left(\frac{mPt}{h} \right)$	$\dot{J}_D \left(\frac{mPt}{s} \right)$	$\dot{J}_{tot} \left(\frac{mPt}{s} \right)$	$f_j (\%)$
Boiler	0.255	0.025	8.957	22.277	22.280	0.011
Turbine	0.025	0.061	25.592	0.003	0.010	71.172
Condenser	0.009	0.068	97.092	0.352	0.355	7.606
Bomb	4.484	0.255	0.177	0.003	0.002	1.725
System	4.417	0.052	----	----	----	----

Figure 4: Relationship between net power and environmental impact

condenser is responsible for the highest ecological rate per component with a value of 0.027 mPt/s. however, according to (Cavalcanti et al., 2022) it has been shown that the environmental impact rate of a component (\dot{Y}) does not significantly affect the total environmental impact ($\dot{J}_{tot,k}$). In the case of the condenser, \dot{Y} it only represents 1.030% of the total environmental impact (22.614 mPt/s).

The exergoecological factors of the components were $>0.90\%$, with the exception of the boiler because the exergy environmental impact rate is attributed to the element and not to the production of pollutants because biomass is considered an energy renewable and does not produce pollutants. Likewise, the ecological impact rate per unit of exergy to generate work was $0.188 \frac{mPt}{kWh}$, which is equivalent to 86.70% lower than the value obtained by (Cavalcanti et al., 2020) in the cogeneration of electricity from biomass such as sugarcane bagasse of sugar.

On the other hand, the effect of the relationship between the net power of the system and the average ecological impact per unit of exergy at the turbine outlet is shown in Figure 4. According to Figure 4 for the net power generated by the system, the ecological impact per unit of exergy at the turbine outlet decreases as the W_{net} of the cycle increases and is explained by the increase in work generated in the turbine because the rate of exergy destroyed decreases and together so does the ecological impact at the turbine output.

From the solution of equation (h) we can show in Table 5. The recommended minimum power so that the environmental impact in the system is the lowest applying the second derivative in Figure 4. It helped us find the inflection point of the data, in this

case, the power required in a thermal power plant to minimize environmental impact, which should be 750000kW.

4. CONCLUSIONS

In the present study, some energetic, exergetic and exergoecological analyzes were carried out for a steam power generation cycle fed with rice husks, which produced a net power of 26.658MW with an energy efficiency of 23.680% and an exergetic efficiency of 12.830%.

The boiler presented an exergy destruction rate of 86.618 MW, which represents 69.047% of the total exergy destruction, in addition, the specific environmental impact of power and steam were, respectively, 0.188 mPt/kWh and 0.244 mPt/kWh.

On the other hand, the highest environmental impact rate associated with exergy destruction occurred in the condenser with a value of 97.092 mPt/h. If the environmental impact of a thermal power plant is to be kept to a minimum, the recommended power output should be 750000 kW.

The system presented an energy and exergetic efficiency according to the literature, but a way to optimize the system and achieve a higher efficiency would be to take advantage of the exhaust gases to reduce the humidity of the biomass, with this, the calorific value could be increased of the biomass and with it the transfer of heat to the fluid that circulates through the cycle would increase.

REFERENCES

- Bejan, A., Tsatsaronis, G., Moran, M.J. (1995), Thermal Design and Optimization. Hoboken, New Jersey: John Wiley and Sons.
- Bilgen, S., Sarikaya, İ. (2015), Exergy for environment, ecology and sustainable development. Renewable and Sustainable Energy Reviews, 51, 1115-1131.
- BOTTA, N. (2012), Explosivity Measurement, Argentina. Available from: https://www.redproteger.com.ar/miscongresos/jornadaincendio2012/medicion_explosividad_nov2012.pdf
- Buelvas, G. (1995), Proposal for the Design and Construction of a Combustion Gas Washing and Purification System, in a Pilot Plant; Absorption-adsorption Method. [Undergraduate Work, Technological University of Sonora of Mexico]. Available from: <https://www.bidi.uson.mx/tesisDet.aspx?crit1=IDUT&texto1=4324&crit2=TITULO&texto2>
- Buitrago, P. (2022), "Clean Energies do not Exceed 1% in the Country's Energy Matrix": Asoenergía (Part 1). More Columbia. Available from: <https://www.mascolombia.com/las-energias-limprias-no-superan-el-1-en-la-matriz-energetica-del-pais-asoenergía-parte-1>
- Cao, Y., Dhahad, H.A., Alsharif, S., Sharma, K., El-Shafay, A.S., Kh, T.I.

- (2022), Development of a MSW-fueled sustainable co-generation of hydrogen and electricity plant for a better environment comparing PEM and alkaline electrolyzers. *Sustainable Cities and Society*, 81, 103801.
- Cavalcanti, E.J.C., Carvalho, M., Azevedo, J.L.B. (2019), Exergoenvironmental results of a *Eucalyptus* biomass-fired power plant. *Energy*, 189, 116188.
- Cavalcanti, E.J.C., Carvalho, M., da Silva, D.R. (2020), Energy, exergy and exergoenvironmental analyses of a sugarcane bagasse power cogeneration system. *Energy Conversion and Management*, 222, 113232.
- Cavalcanti, E.J.C., Carvalho, M., Ochoa, A.A.V. (2019), Exergoeconomic and exergoenvironmental comparison of diesel-biodiesel blends in a direct injection engine at variable loads. *Energy Conversion and Management*, 183, 450-461.
- Cengel, Y.A., Boles, M.A. (2009), *Thermodynamics*. 6th ed. Mexico: McGraw-Hill.
- Dincer, I., Zamfirescu, C. (2012), Renewable-energy-based-multigeneration systems. *International Journal of Energy Research*, 36(15), 1403-1415.
- Food and Agriculture Organization of the United Nations [FAO]. (2018), *FAO Rice Market Monitoring*. Rome, Italy: Food and Agriculture Organization of the United Nations. Available from: <https://www.fao.org/3/i9243es/I9243ES.pdf>
- Goedkoop, M., Effting, S., Collignon, M. (2000), *The Eco-indicator 99: A Damage Oriented Method for Life-cycle Impact Assessment: Manual for Designers*. Netherlands: PRé Sustainability.
- Gutiérrez, A.S., Eras, J.J.C., Santos, V.S., Herrera, H.H., Hens, L., Vandecasteele, C. (2018), Electricity management in the production of lead-acid batteries: The industrial case of a production plant in Colombia. *Journal of cleaner production*, 198, 1443-1458.
- He, F., Liu, X., Wang, M., Zhou, S., Heydarian, D. (2022), Energy, exergy, exergoeconomic, and environmental analyses and multi-objective optimization of a biomass-to-energy integrated thermal power plant. *Alexandria Engineering Journal*, 61(7), 5629-5648.
- Kamari, M.L., Maleki, A., Daneshpour, R., Rosen, M.A., Pourfayaz, F., Nazari, M.A. (2023), Exergy, energy and environmental evaluation of a biomass-assisted integrated plant for multigeneration fed by various biomass sources. *Energy*, 263, 125649.
- Marrugo, S.M.R., Vicent, J.F.S. (2014), *Analysis of the Cost of the KW Generated and the Behavior of the Thermal and Energy Indexes of a CTE that has Steam Overheating and Overheating, a Regeneration System and Three (3) Cylinder Condensation TV*. [Undergraduate Work, Technological University of Bolivar of Colombia]. Available from: <https://www.repositorio.utb.edu.co/handle/20.500.12585/1276>
- Méndez, M.C.V. (2010), *Characterization of the Rice Husk to Use as Renewable Energy in Gasification*. [Undergraduate Work, Universidad de los Andes de Colombia]. Available from: <https://www.repositorio.uniandes.edu.co/bitstream/handle/1992/24547/u419491>
- Meyer, L., Tsatsaronis, G., Buchgeister, J., Schebek, L. (2009), Exergoenvironmental analysis for evaluation of the environmental impact of energy conversion systems. *Energy*, 34(1), 75-89.
- Morris, D.R., Steward, R., Szargut, J. (1988), *Analysis of Thermal, Chemical, and Metallurgical Processes*. New York; Hemisphere. p297-309.
- Nasruddin, N., Saputra, I.D., Mentari, T., Bardow, A., Marcelina, O., Berlin, S. (2020), Exergy, exergoeconomic, and exergoenvironmental optimization of the geothermal binary cycle power plant at Ampallas, West Sulawesi, Indonesia. *Thermal Science and Engineering Progress*, 19, 100625.
- Quintero, L.A.L. (2017), *Evaluation of the Energy Potential of Agro-industrial Solid Waste from the African Palm Oil Extraction Process as an Energy Alternative to Replace Firewood in the Northern Area of the Department of Cesar*. [Master's Degree Work, Manizales University of Colombia]. Available from: <https://www.ridum.umanizales.edu.co/xmlui/handle/20.500.12746/3286>
- Quispe, I., Navia, R., Kahhat, R. (2019), Life Cycle Assessment of rice husk as an energy source. A Peruvian case study. *Journal of Cleaner Production*, 209, 1235-1244.
- Rhenals, J. D., Torres, M. L. (2016), Análisis exergoeconómico de la gasificación de tusa de maíz empleando vapor de agua como agente gasificante, integrado a un sistema de generación de potencia. <https://repositorio.unicordoba.edu.co/handle/ucordoba/669>
- Rostami, M., Manshadi, M.D., Farajollahi, A.H., Marefati, M. (2022), Introducing and evaluation of a new propulsion system composed of solid oxide fuel cell and downstream cycles; usage in Unmanned Aerial Vehicles. *International Journal of Hydrogen Energy*, 47(28), 13693-13709.
- Shafie, S.M., Mahlia, T.M.I., Masjuki, H.H., Rismanchi, B. (2012), Life cycle assessment (LCA) of electricity generation from rice husk in Malaysia. *Energy Procedia*, 14, 499-504.
- Singh, O.K. (2020), Application of Kalina cycle for augmenting performance of bagasse-fired cogeneration plant of sugar industry. *Fuel*, 267, 117176.
- Valverde, A., Sarria, B., Monteagudo, J.P. (2007), Comparative analysis of the physicochemical characteristics of rice husk. *Scientia Technica*, 1, 255-260.